

**COMPLETE and FULLY INTEGRATED
AIR PRESSURE CONTROL
& MONITORING
SYSTEMS**



BREATHE EASY

- **Controllers**
- **Monitors**
- **Venturi Valves**
- **Sensors**
- **and More**

Triatek began in 1985 by offering customers forward thinking controls featuring the latest software and hardware. Subsequently, customers quickly embraced Triatek globally and recognized the company as a pioneering force in controls. It is this same technology-centric focus that permeates throughout Triatek today and as a result, Triatek continues to offer the most sophisticated, accurate and easy to use controllers and monitors today.

THE EVOLUTION

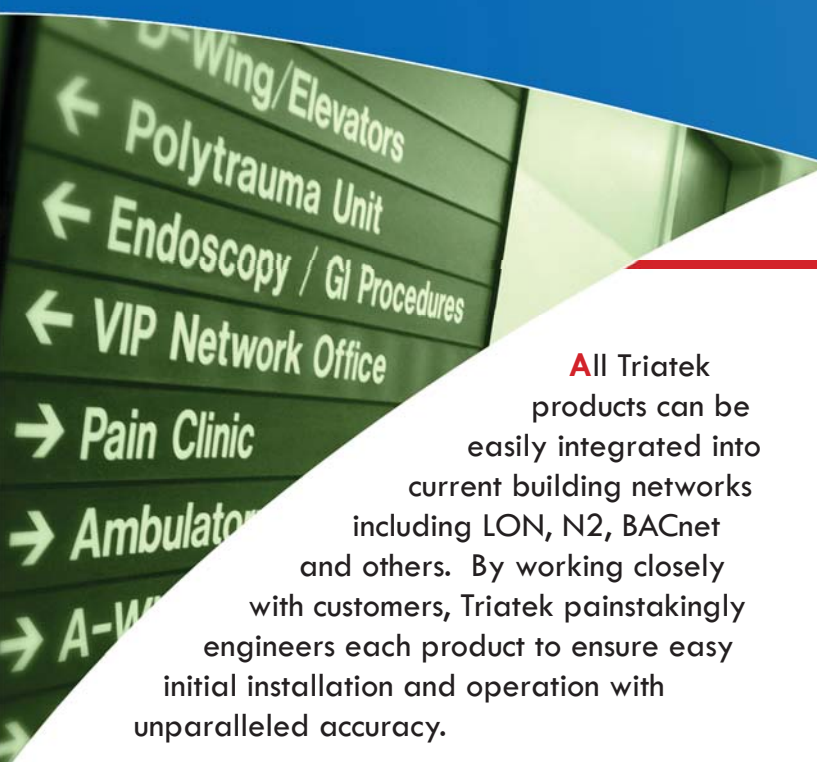

All Triatek products can be easily integrated into current building networks including LON, N2, BACnet and others. By working closely with customers, Triatek painstakingly engineers each product to ensure easy initial installation and operation with unparalleled accuracy.

These and other efforts have resulted in rapid acceptance of Triatek products on a global scale by the most well-known and respected medical institutions. And only Triatek can offer a truly integrated, end-to-end solution with components designed to seamlessly operate with each other in perfect symphony for maximum protection

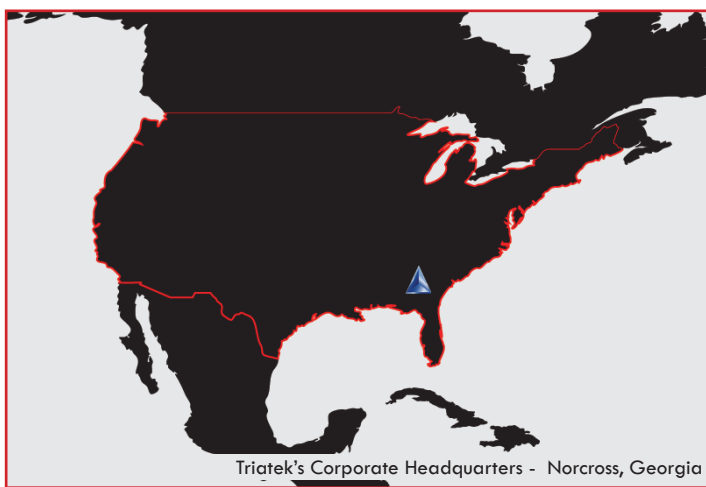

while helping to keep energy costs to a minimum. No other single company can match the breadth and depth of our line of controllers, monitors and venturi valves.

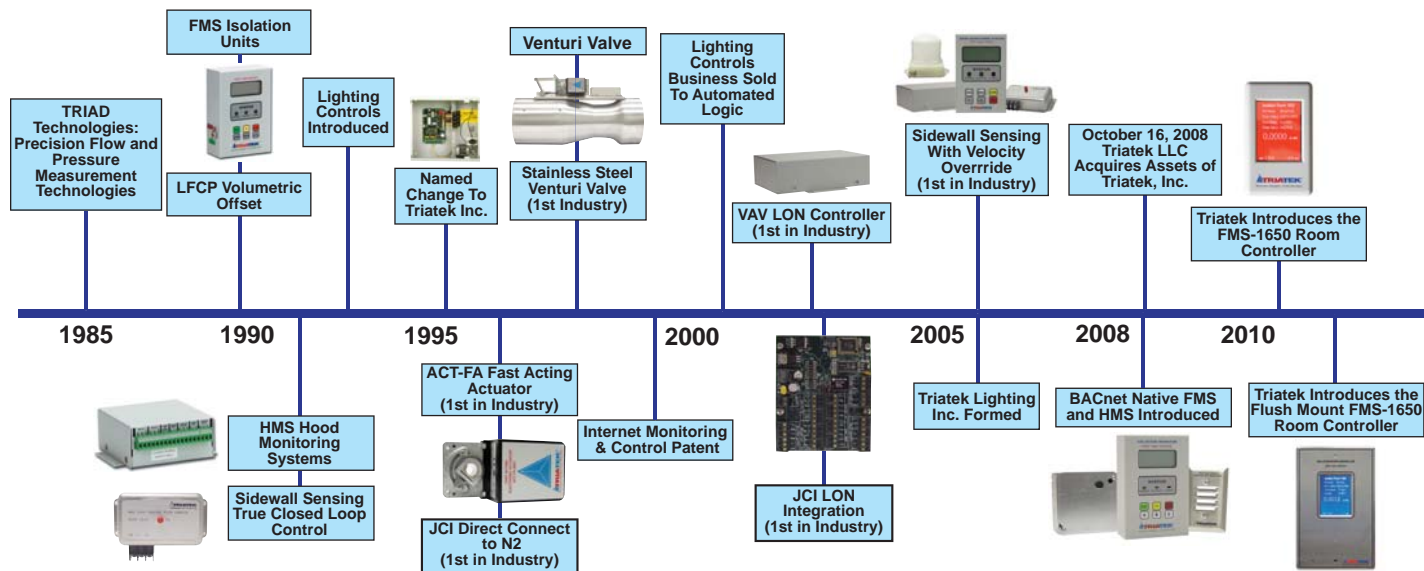

Triatek's Product Development Over the Years

EMERGENCY

EMERGENCY

HOSPITALS & LABORATORIES

Triatek's desire to use the latest technology in order to develop the most advanced, safest and easiest to use systems has resulted in an adoption rate well above industry averages for the last ten years.

In fact, Triatek was the leader in developing "closed-loop" fume hood systems whereby the fume hood controller continuously monitors and adjusts for both a sash position and an air velocity sensor. Most other systems on the market only use a sash position sensor; and therefore, potentially exposes workers to fumes whenever sash openings are partially covered and not taken into consideration by the fume hood controller.



Triatek's Fifth Generation 1650 Series Controllers and Monitors

- RESEARCH CENTERS & LABORATORIES
- PHARMACEUTICAL MANUFACTURING
- MEDICAL DEVICE MANUFACTURING
- CLEAN ROOMS & ANTEROOMS
- CRITICAL CARE ROOMS
- OPERATING ROOMS
- ISOLATION ROOMS
- FUME HOODS

Triatek continues its tradition of engineering precision instruments designed specifically for areas requiring exacting accuracy. The latest 1650 Series of controllers and monitors represent a significant leap forward by combining sensitivity and accuracy in an easy-to-use package. It is this forward thinking that continues to propel Triatek today and is also why Triatek is relied on around the world to protect employees and patients from dangerous airborne particles and deadly fumes.

All of Triatek's latest controllers use full-color touch screens allowing for easier setup, faster adoption by staff, and more information at a glance than any other controller on the market today.

CONTROLLERS

FMS-1650 Series Room Controllers

Available as either a flush-mounted or surface-mounted unit, these controllers can be integrated into existing building automation systems (i.e. LON, BACnet or N2 networks) or act as stand-alone controllers. Highly adaptable, these units feature up to 6 analog and 4 digital inputs in addition to 4 PID and 4 relay outputs for increased integration flexibility. A thin profile, stainless steel version is also available for walls with cavities under 2 inches.



FMS-1650 Stainless Steel Flush Mount Controller

HMS-1650 Fume Hood Controllers

Triatek's latest fume hood controller provides a truly closed loop solution for greater accuracy and control. In fact, it was Triatek who perfected using both sash and air velocity sensing to better regulate air entering the fume hood. Easy to use as a stand-alone or when fully integrated into LON, BACnet or N2 networks, the HMS-1650 measures 0-200 FPM and is accurate to within +/- 2 FPM within normal operating ranges.

In addition to 2 thermister inputs, the HMS-1650 Fume Hood Controller has 4 analog inputs, 4 analog outputs, 4 digital inputs, and 4 digital outputs on-board to make integration easier and more cost effective.



HMS-1650 Surface Mount Fume Hood Controller

VAV Controllers

Pre-determined supply and exhaust air offset are easily controlled using the Triatek VAV1000L. Programmed using LON based software, this unit features non-volatile memory so all values and settings are retained in the event of a power failure.

For greater installation possibilities, this unit features 4 analog inputs, 4 analog outputs, 4 digital inputs, 4 relay outputs and 3 PID loops.



VAV1000L With Cover Removed

ROOM MONITORS

CMS-1650 Central Monitoring Stations

Capable of simultaneously monitoring up to 4 individual FMS-1650 controllers, the CMS-1650 is typically used at a nurse's station or wherever multiple rooms require monitoring. Each of the FMS-1650 controllers are connected via a 4 conductor cable, the nearest of which is terminated at the CMS-1650.



CMS-1650 Stainless Steel Central Monitoring Station

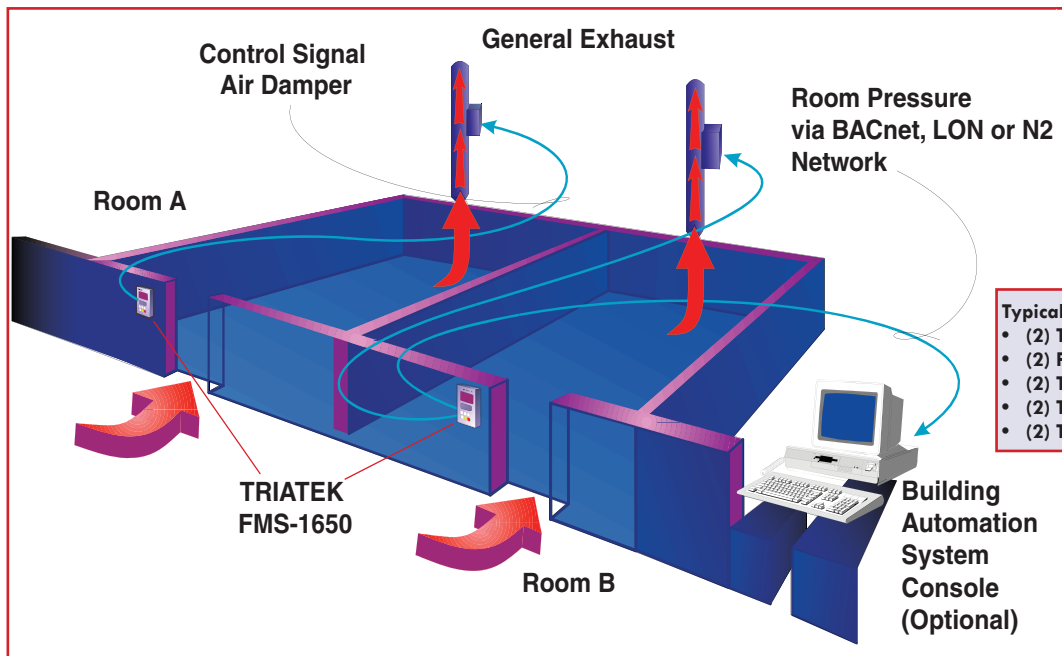

Typical Double Isolation Requirements:

- (2) Triatek Venturi Valves
- (2) FMS-1650 Room Controllers
- (2) Triatek Temperature Sensors
- (2) Triatek External Pressure Sensors
- (2) Triatek Actuators



FMS-1650-R Surface Mount Remote Monitor

FMS-1650-R Remote Room Monitors

Similar to the CMS-1650, the FMS-1650-R is a fully programmable remote display and can be configured to show just those room parameters that require constant surveillance. Wired directly to the FMS-1650 room controller, the FMS-1650-R is password protected and has both visual and audible alarm notifications.

Because they are highly sensitive instruments, Triatek Venturi Air Valves are relied on by hospitals and laboratories around the world to protect employees and patients from dangerous airborne particles and deadly fumes.



VENTURI VALVES

The Triatek Venturi Air Valve is a pressure-independent, variable volume valve that maintains a desired air volume independent of static pressure changes at the valve. Accurate to within +/- 5%, Triatek Venturi Air Valves have been counted on by companies around the world for their air flow control in critical environments.

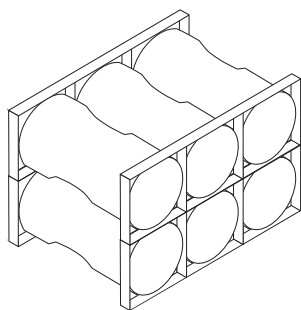

Now Available - Low Flow and Shut-Off Venturi Valves! Contact Triatek for more information.



Reinforced struts for additional support and strength.

Rapid response electronic actuator for better flow regulation.

Aluminium, stainless steel or Heresite construction options available.

Finishing / Construction Options					Flow Rates		Assembling Options
Size	Sound Insulation	Heresite	Stainless Steel	Teflon Coated	Min Flow/Valve (cfm)	Max Flow/Valve (cfm)	Can Be Ganged
6"	✓	✓	✓	✓	30	250	X
8"	✓	✓	✓	✓	35	700	X
10"	✓	✓	✓	✓	50	1000	✓
12"	✓	✓	✓	✓	90	1500	✓
14"	✓	✓	✓	✓	175	2100	✓

INTEGRATED SOLUTIONS

While other companies offer only a part of an air pressure solution, Triatek engineers and sells a complete end-to-end solution including venturi valves, controllers, monitors, room and fume hood sensors, actuators, network gateways and more. In fact, all of our products are designed to flawlessly synchronize with each other for maximum efficiency. While all Triatek components are designed to be used as a complete system, individual Triatek components have been engineered to allow plug-n-play functionality with already installed systems. Even legacy or antiquated systems using older networking protocols can easily be modernized or retrofitted with the latest technology using Triatek componentry.





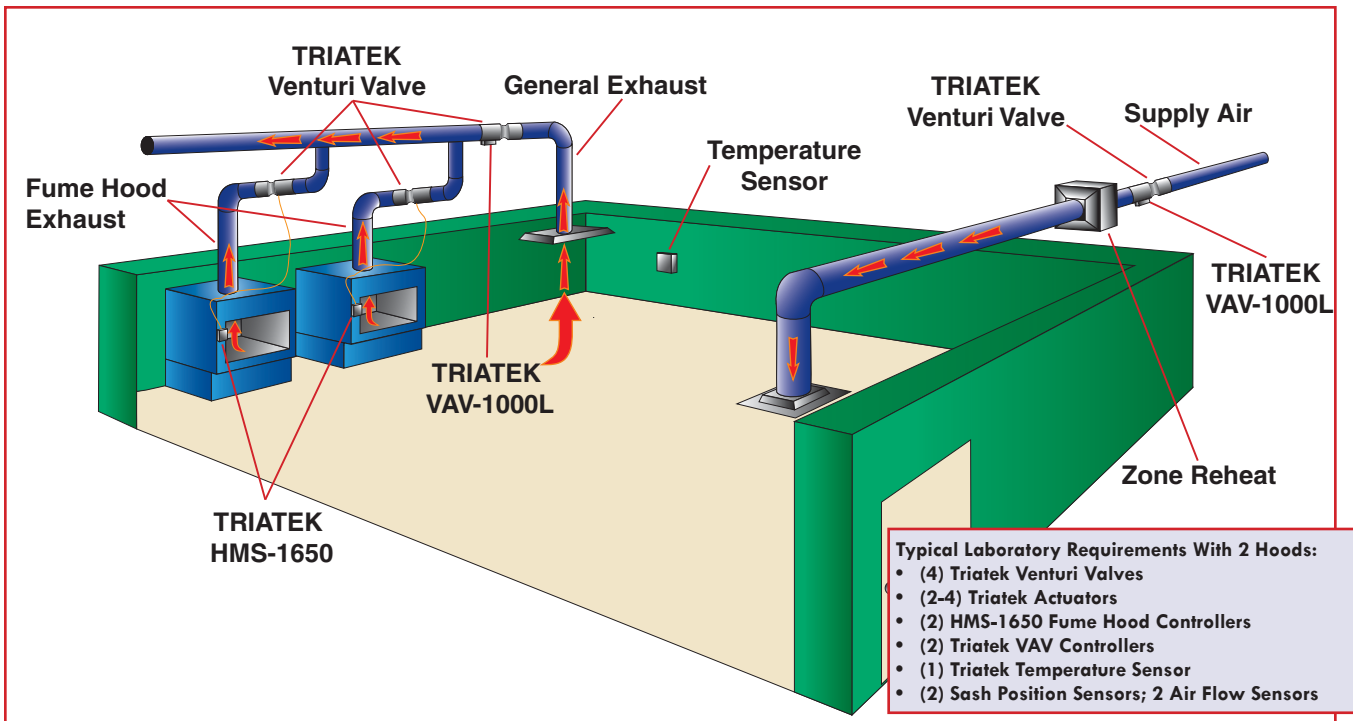



Call Triatek, or one of our local sales agents, to better understand how new Triatek componentry can improve your energy efficiency while also increasing safety levels for your employees.



All Triatek products are designed to withstand years of service in the most critical of environments without any annual maintenance or adjustments. Once installed and configured, Triatek valves, monitors and controllers provide customers both peace of mind and energy efficiency. Below is a chart which highlights the fundamental differences between each of these products.



1650 Series: AT A GLANCE

MODEL	MONITORS (M) OR CONTROLS (C) OR NOT AVAILABLE (-)								# OF CONNECTIONS				NETWORK	SPECIAL REQUIREMENTS
	Pressure	Temp.	Air Changes	Humidity	Isolation Mode	Room Status	Sash Height	Air Velocity	Analog Inputs	Analog Outputs	Digital Inputs	Relay Outputs		
FMS1650-LITE 	M	-	-	-	M	M	-	-	0	0	0	0	No	None
FMS1650-x-R 	M	M	M	M	M	M	-	-	0	0	0	0	Yes	(1) FMS1650 Host Controller
FMS1650 	C	C	M	C	C	M	-	-	6	4	4	4	Yes	None
CMS1650 	M	M	M	M	M	M	-	-	0	0	0	0	Yes	(1) to (4) FMS1650 Host Controller(s)
HMS1650-LITE 	-	-	-	-	M	M	M	M	0	0	0	0	No	(1) Sash Height Sensor and (1) Sidewall Velocity Sensor
HMS1650 	-	C	-	M	C	C	M	C	6	4	4	4	Yes	(1) Sash Height Sensor and/or (1) Sidewall Velocity Sensor

Triatek has an extensive network of manufacturer's representatives located throughout North America to service you. Our helpful, experienced sales team can provide solutions for your Laboratory Controls, Medical Controls, and Industrial Instrumentation needs.

Call **770-242-1922** or visit **www.triatek.com** for more information or to find an agent near you.

Your Local Triatek Representative